

■ Electric Pallet truck ,Walkie Operation TB15-WA1



Safety & Efficient

- With stepless speed regulation system, the speed change is more stable.
- Without load and with heavy load ,Speed can be maintained as the same.
- Floating balance wheel avoid lateral shaking when walking without load.
- Energy consumption braking improve the reliability and the working life of brake.

Excellent performance

- Good climbing performance.
- Brushless motor with high electric efficiency , maintenance free.
- Horizontal drive wheel provides convenient replacement.
- Max speed limit button can release brake when handle upright, reduce turning space greatly, suitable for the operation in narrow space.

Comfortable & practical

- Beautiful appearance and beautiful curve.
- Full sealed battery free for maintaining, big capacity.
- Convenience for Maintenance change disadvantage of difficulty in maintenance.
- With forklift mounted charger the forklift can be charged in any place with socket.

MACHINE 2D GRAPH

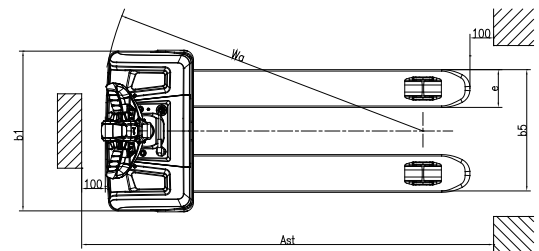
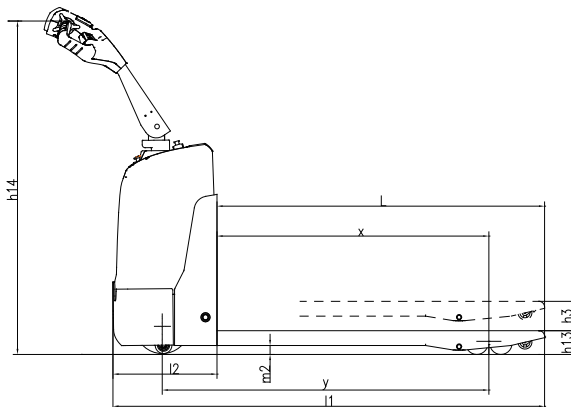

IDENTIFICATION		TB15 - WA1
Drive	-	electric
Operator type	-	Pedestrian
Load Capacity/rated load	Q(kg)	1500
Load centre distance	c(mm)	600
Load distance(raised)	x(mm)	847/917
Wheelbase(lowered)	Y(mm)	1152/1222
WEIGHT		
Service weight (including battery)	kg	230
Axle loading, laden, front/rear	kg	889/841
Axle loading, unladen, front/rear	kg	194/36
WHEEL CHASSIS		
Tyres Type	-	polyurethane
Wheel size, front	-	Φ195
Wheel size, rear	-	Φ80/Φ74
Additional wheels	-	-
Wheels, number front/rear (x=driven wheels)	-	1X+2/4
Track width, front	b ₁₀ (mm)	-
Track width, rear	b ₁₁ (mm)	360/390/525
DIMENSIONS		
Lift height	h ₃ (mm)	105
Height of tiller, in drive position, Min. /Max.	h _{14t} (mm)	950/1310
Height, fork lowered	h ₁₃ (mm)	85/75
Overall length	l ₁ (mm)	1508/1578
Length to face of forks	l ₂ (mm)	358
Overall width	b ₁ (mm)	685
Fork dimensions	S/e/l(mm)	53/160/1150(1220)
Width across forks	b ₅ (mm)	520/550/685
Ground clearance ,Centre of wheelbase	m ₂ (mm)	32/22
Aisle width for pallets 1000x1200 crossways	A _{st} (mm)	1708/1778
Aisle width for pallets 800x1200 lengthways	A _{st} (mm)	1758/1778
Turning radius	W _a (mm)	1320/1389
PERFORMANCE		
Travel speed, laden/unladen	Km/h	5.3/5.8
Lift speed, laden/unladen	m/s	0.035/0.045
Lowering speed, laden/ unladen	m/s	0.080/0.037
Max. gradeability, laden/unladen	%	5/15
Service brake	-	Electromagnetic
MOTOR		
Drive motor power	kW	0.9
Lift motor power	kW	0.8
Battery voltage/rated capacity	V/Ah	24/80
Battery weight	Kg	49
OTHERS		
Type of dirve control	-	DC
Sound level at the driver' sear according to DIN12053	dB(A)	70

The company reserves the right to modify the provision of parameters, such as a change without notice.